

Suggested cables:



CODE:  
**CAB-M12FD5A3R**  
PVC 5 poles M12 female straight cable

CODE:  
**CAB-M12FA5A3R**  
PVC 5 poles M12 female angled cable

**OPERATING TEMPERATURE:** -25°C / +80°C  
**HOUSING / MOLDED BODY:** TPU  
**INSERT:** TPU  
**CONTACT:** CuSn pre-nickel and 0.3 microns gold-plated  
**KNURLED SCREW:** CuZn, nickel-plated  
**O-RING:** FKM  
**PROTECTION DEGREE:** IP67 in locked position  
**CONTACT RESISTANCE:** ≤ 5 mΩ  
**NOMINAL CURRENT AT 40°C:** 4 A  
**NOMINAL/RATED VOLTAGE:** 240 V / 250 V  
**TEST VOLTAGE:** 2.0 kV eff. /60 s  
**INSULATION RESISTANCE:** > 10<sup>9</sup> Ω  
**POLLUTION DEGREE:** 3

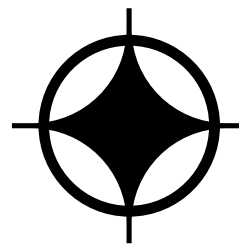

**Pixsys**<sup>®</sup>  
ELECTRONICS

**CODE:** PPS--1/10BR-1-1-1-A1  
**DESCRIPTION:** Compact and highly configurable Pressure Transducer designed for mid-high volume OEM applications to provide uncompromised performance

**POWER SUPPLY:** 15..30VDC  
**CONSUMPTION:** Max 0.8 W  
**MATERIAL:** Sensor housing steel galvanised  
**WEIGHT:** Approx. 189 g  
**SEALING:** IP65  
**MEASURING RANGE:** -1..10 Bar Relative  
**SENSOR TYPE:** Thin film on steel  
**ELECTRIC CONNECTION:** 5 Pole Male M12x1 / 4 Pole DIN 43650  
**SENSOR WORKING TEMP.:** - 20..+ 85°C (A2) / - 40..+ 125°C (A1)  
**ACCURACY:** ± 1.0% of Span: 0° C to 85°C (32° F to 185° F)  
 ± 2.0% of Span: 85° C to 125° C (185° F to 257° F)  
 ± 2.0% of Span: -40° C to -20° C (-40° F to -4° F)  
 Includes the combined effects of non-linearity (Terminal Point Method), hysteresis, non-repeatability, temperature and zero offset and span setting errors

**OUTPUT:** 1 analogue 4..20mA

**Ordering Code:**

**PPS-1/10BR-1-1-1-A1**

Examples:  
 1.3BR = -1..3 Bar RELATIVE  
 0.1BR = -1..100 mBar RELATIVE  
**-1/10BR = -1..10 Bar RELATIVE**  
 0.1BA = 0..100 mBar ABSOLUTE  
 10BA = 0..10 Bar ABSOLUTE

Pressure connection  
**1 = 1/4" Gas**  
 2 = 1/2" Gas  
 3 = 1/4" NPT  
 4 = 1/2" NPT  
 5 = 1/2" Gas Flush Membrane  
 6 = 1" Gas Flush Membrane

Range  
 1 = M12 4 pin  
 2 = M12 5 pin  
 3 = EN 175301-803 Form A (DIN 43650, Form A)  
 4 = EN 175301-803 Form C (DIN 43650, Form C)

Electrical Connections  
**1 = 4..20 mA**  
 2 = 0..10 Volt  
 3 = 0..20 mA

Analogue output  
**1 = 4..20 mA**  
 2 = 0..10 Volt  
 3 = 0..20 mA

A1	size
-1..0 Bar	1
<b>-1..10 Bar</b>	<b>1</b>
-0..5..10 Bar	1
0..1 Bar	1
0..2,5 Bar	1
0..4 Bar	1
0..6 Bar	1
0..10 Bar	2
0..16 Bar	2
0..25 Bar	2
0..40 Bar	2
0..100 Bar	2
0..160 Bar	2
0..250 Bar	2
0..400 Bar	2
0..600 Bar	2

**Pixsys srl**  
 Via Po, 16  
 30030 - Mellaredo di Pianiga  
 Venezia - Italia  
 Tel. +39 041 5190518  
 Fax +39 041 519002  
 Mail info@pixsys.net  
 www.pixsys.net



Document version: rel.01  
 Last update: 30/07/2023  
 Author: Matteo Cardi

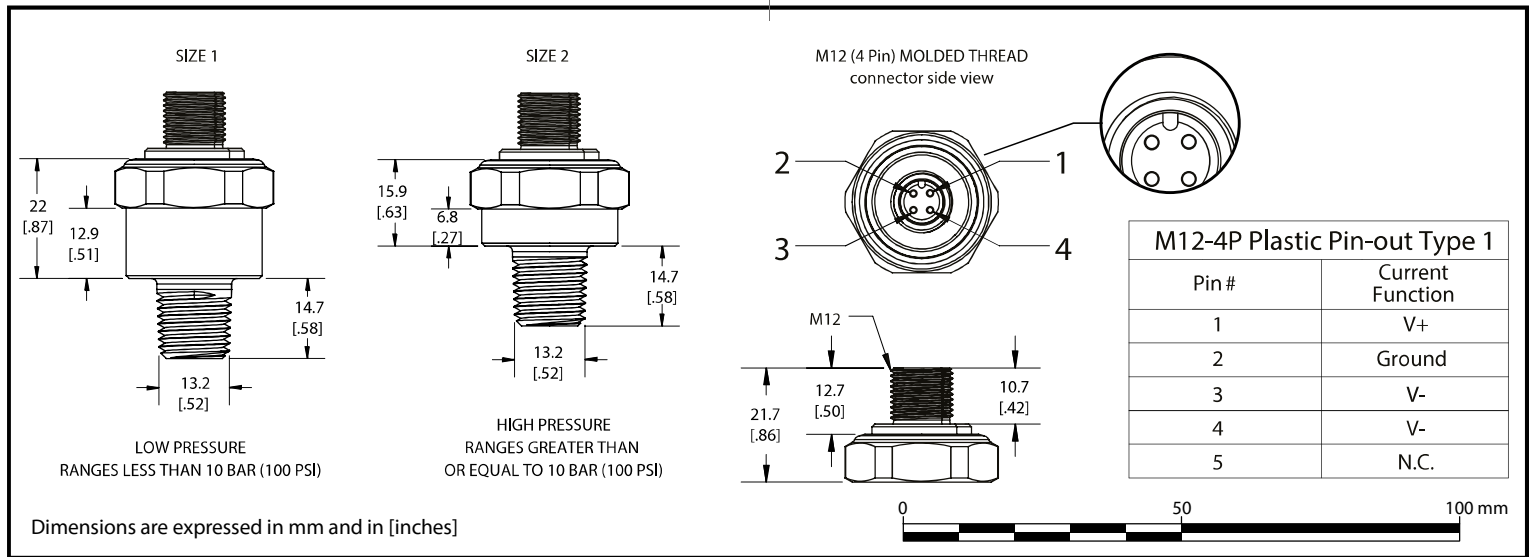

**WARNING! READ CAREFULLY BEFORE INSTALLATION**

**1. GENERAL:**

If the PPS is used in a manner not specified by Pixsys srl, the protection provided by the unit may be impaired. A failure resulting in injury or damage may be caused by excessive overpressure, excessive vibration or pressure pulsation, excessive instrument temperature, corrosion of the pressure containing parts, or other misuse. Consult Pixsys srl before installing if there are any questions or concerns.

**2. OVERPRESSURE:**

Pressure spikes in excess of the rated overpressure capability of the transducer may cause irreversible electrical and/or mechanical damage to the pressure measuring and containing elements.

Fluid hammer and surges can destroy any pressure transducer and must always be avoided. A pressure snubber should be installed to eliminate the damaging hammer effects. Fluid hammer occurs when a liquid flow is suddenly stopped, as with quick closing solenoid valves. Surges occur when flow is suddenly begun, as when a pump is turned on at full power or a valve is quickly opened.

Liquid surges are particularly damaging to pressure transducers if the pipe is originally empty. To avoid damaging surges, fluid lines should remain full (if possible), pumps should be brought up to power slowly, and valves opened slowly. To avoid damage from both fluid hammer and surges, a surge chamber should be installed.

Symptoms of fluid hammer and surge's damaging effects:

- Pressure transducer exhibits an output at zero pressure (large zero offset).
- Pressure transducer output remains constant regardless of pressure
- In severe cases, there will be no output.

**FREEZING:**

Prohibit freezing of media in pressure port. Unit should be drained (mount in vertical position with electrical termination upward) to prevent possible overpressure damage from frozen media.

**3. STATIC ELECTRICAL CHARGES:**

Any electrical device may be susceptible to damage when exposed to static electrical charges. To avoid damage to the transducer observe the following:

- Ground the body of the transducer BEFORE making any electrical connections.
- When disconnecting, remove the ground LAST!

Note: The shield and drain wire in the cable (if supplied) is not connected to the transducer body, and is not a suitable ground.

**DESCRIPTION**

The Model PPS pressure transducers are high performance instruments intended for use in industrial applications where the process media is compatible with the 17-4PH Stainless steel sensor material and either the 304 Stainless steel, carbon steel, brass or aluminum process connection depending on which option is used.

**MECHANICAL INSTALLATION**

**Environmental**

The PPS pressure transducer can be stored and used within the temperature limits of -40 °C to 125 °C (-40 °F to 257 °F). Ingress protection ratings of the units are dependent on the electrical termination specified. Refer to the wiring diagrams on the reverse for the IP rating of the unit which is being installed.

**Mounting**

The PPS pressure transducers require no special mounting hardware and can be mounted in any orientation with negligible position error. Although the units can withstand considerable vibration without damage or significant output effects, it is always good practice to mount the transducer where there is minimum vibration. For units with NPT type pressure fittings apply sealing tape or an equivalent sealant to the threads before installing. When installing or removing the unit apply a wrench to the hex wrench flats, located above the pressure fitting.

DO NOT tighten by using a pipe wrench on the housing. A 27mm (1 1/16") wrench can be used on the wrench flats of the hex.

**Electro-Magnetic Interference**

The circuitry of the PPS pressure transducers is designed to minimize the effect of electromagnetic and radio frequency interference. To minimize susceptibility to noise, avoid running the termination wiring in a conduit which contains high current AC power cables. Where possible avoid running the termination wiring near inductive equipment.

**Field Adjustments**

The PPS pressure transducers are precisely calibrated and temperature compensated at the factory to ensure long and stable performance. There are no field accessible adjustments on the transducers.

**PPS ELECTRICAL INSTALLATION**

**Wiring Diagram**

(see following pages for further details)

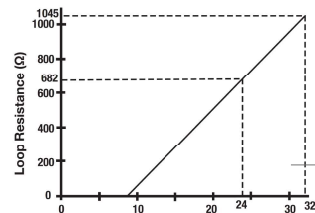
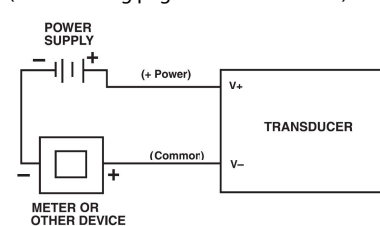

**Power Supply Requirements:**

Output Signal	Min Supply	Max Supply
4-20 mA	9 Vdc	32 Vdc

Where shielded wiring is being used, connect the drainwire to the guard terminal on the read out device or measuring instrument if available. In all other cases connect to the ground of the power supply negative terminal.

For transmitters with 4-20 mA output signal, the minimum voltage at the terminals is 9 Vdc. However, the minimum supply voltage should be calculated using the graph here above and the following formula:

$$V_{MIN} = 9V + [0.022A * x (RL)]$$

(\*includes a 10% safety factor)

$$RL = RS + RW$$

RL = Loop Resistance (Ohms)

RS = Sense Resistance (Ohms)

**4. MEDIA COMPATIBILITY & GALVANIC COMPATIBILITY**

All configurations of the PPS that utilize housing/fitting materials including zinc plated carbon steel, brass and aluminum are dissimilar to the 17-4PH Stainless steel sensor element. Both the housing/fitting material and the sensor element are in direct contact with the process media. If the process media is an electrolytic solution, galvanic corrosion may occur. Selected materials should be carefully reviewed by the user of this product for both individual chemical compatibility with the process media, as well as combined use to avoid galvanic corrosion.

**COMPLIANCE**

